

The background features a dark grey field with white line-art illustrations of various promotional items: a large tote bag, a shopping bag, a stack of books, a pair of sunglasses, and a gift box. On the left side, there are large, overlapping geometric shapes in red and grey, resembling stylized arrows or abstract forms.

ARTÍCULOS PROMOCIONALES

CATÁLOGO



PROMOTIER[®]

Promocionales Premium

**SOMOS
FABRICANTES
DE ARTÍCULOS
PROMOCIONALES
TEXTILES DESDE 1989.**

Promotier.mx

PPAI
The Mark of a Professional.

SAGE[®]
SUPPLIER MEMBER

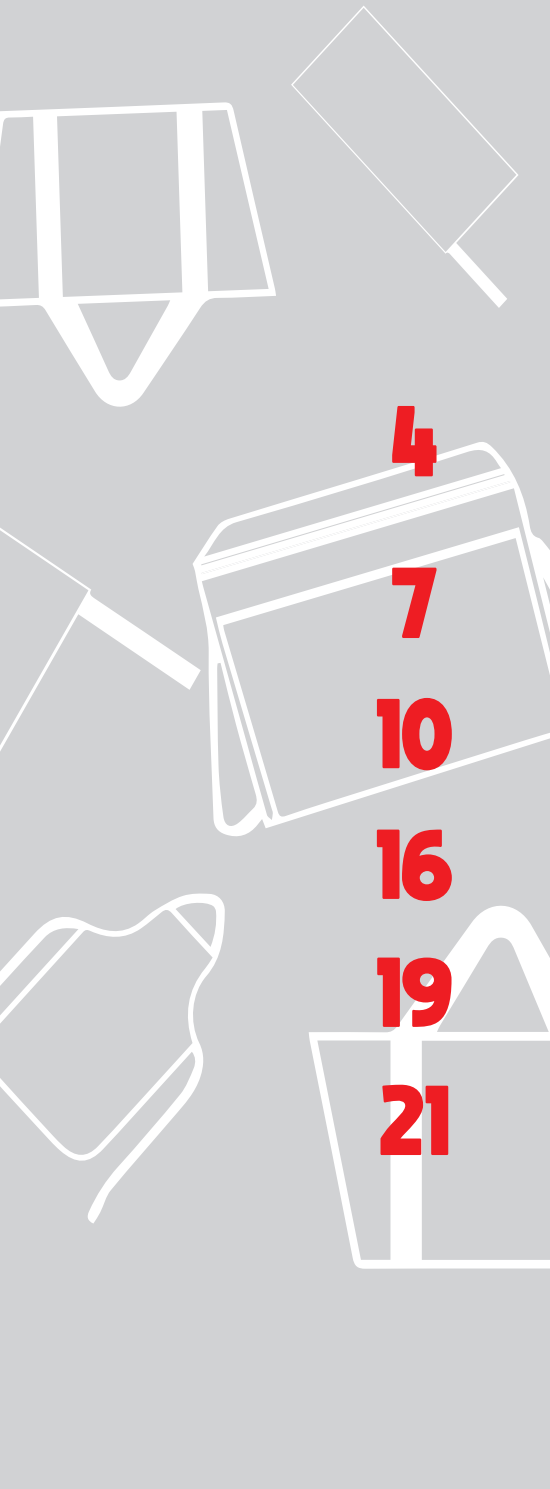

Información

Térmicos

Hieleras

Mandiles

Bolsas

Portafolios

ÍNDICE

¿QUIÉNES SOMOS?

Somos una empresa líder en la fabricación de artículos promocionales textiles desde 1989. Somos fabricantes de loncheras, bolsas, hieleras, mandiles, portafolios, porta bebidas que puedes personalizar por completo.

NUESTROS PRODUCTOS



Ofrecemos un portafolio de artículos promocionales innovadores y de la más alta calidad enfocados a las necesidades de nuestros clientes.



Te damos la oportunidad de escoger y personalizar nuestros productos a tu medida, para potenciar tus ideas al máximo.



Estamos comprometidos con los principios de desarrollo sustentable y la ecología.

NUESTRA EXPERIENCIA

Ponemos a tu disposición más de 30 años de experiencia siendo líderes en la fabricación de artículos promocionales textiles.

30
AÑOS

CONTROL DE CALIDAD

Nuestros productos son manufacturados con los más altos estándares internacionales de calidad.

MIX AND MATCH

Gran posibilidad de combinaciones a tu gusto.

| | | | | | | | | | | | | | | | | | | | |
|----------------------|-------|-------|------|-----------|-----|-------|------|--------|--------|------|-------|------------|--|--|--|--|--|--|--|
| CURPIEL | Black | | | | | | | | | | | | | | | | | | |
| NEOPRENO TERMICO | Black | | | | | | | | | | | | | | | | | | |
| ECOPRENO TERMICO | Black | White | Blue | Dark Blue | Red | Green | | | | | | | | | | | | | |
| CINTA | Black | White | Blue | Dark Blue | Red | Green | Grey | Yellow | Orange | Pink | Brown | Dark Brown | | | | | | | |
| HEAVY DUTY POLIESTER | Black | White | Blue | Dark Blue | Red | Green | Grey | Yellow | Orange | Pink | Brown | Dark Brown | | | | | | | |
| SOFT POLIESTER | Black | White | Blue | Dark Blue | Red | Green | Grey | Yellow | Orange | Pink | Brown | Dark Brown | | | | | | | |
| BIES | Black | White | Blue | Dark Blue | Red | Green | Grey | Yellow | Orange | Pink | Brown | Dark Brown | | | | | | | |

PROYECTOS ESPECIALES

Al ser fabricantes, le ofrecemos diferentes opciones de telas y diferentes colores, de modo que, tendrá usted la posibilidad de crear su propio estilo dentro de su negocio.



PROYECTOS ESPECIALES



Te damos la oportunidad de personalizar nuestros productos a tu medida.



Térmicos



PORTABOTE TÉRMICO



PORTAMEDIA TÉRMICO

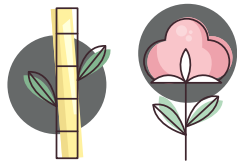

Material exterior Jersey
Poliester. Interior isotérmico
Scuba Foam Econeopreno

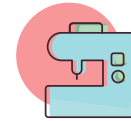
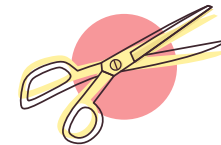

Portamedia térmico
fabricado con bias y zipper
tracero

Impresion de larga
duracion en serigrafía o
dtf



Tiempo de fabricación
y salida de 10 a 15
dias habiles

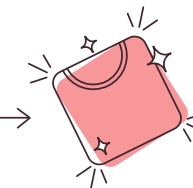

Pedido minimo
desde 50 pzs

Colores de
cuerpo &/o bias

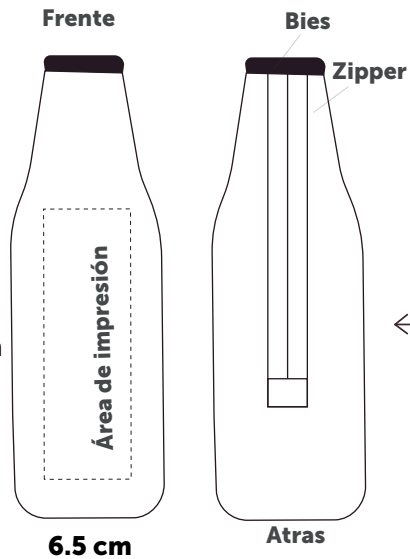

20.5 cm

Frente

Bies

Zipper

6.5 cm

Atras



TORTILLERO TÉRMICO PARA RESTAURANTE

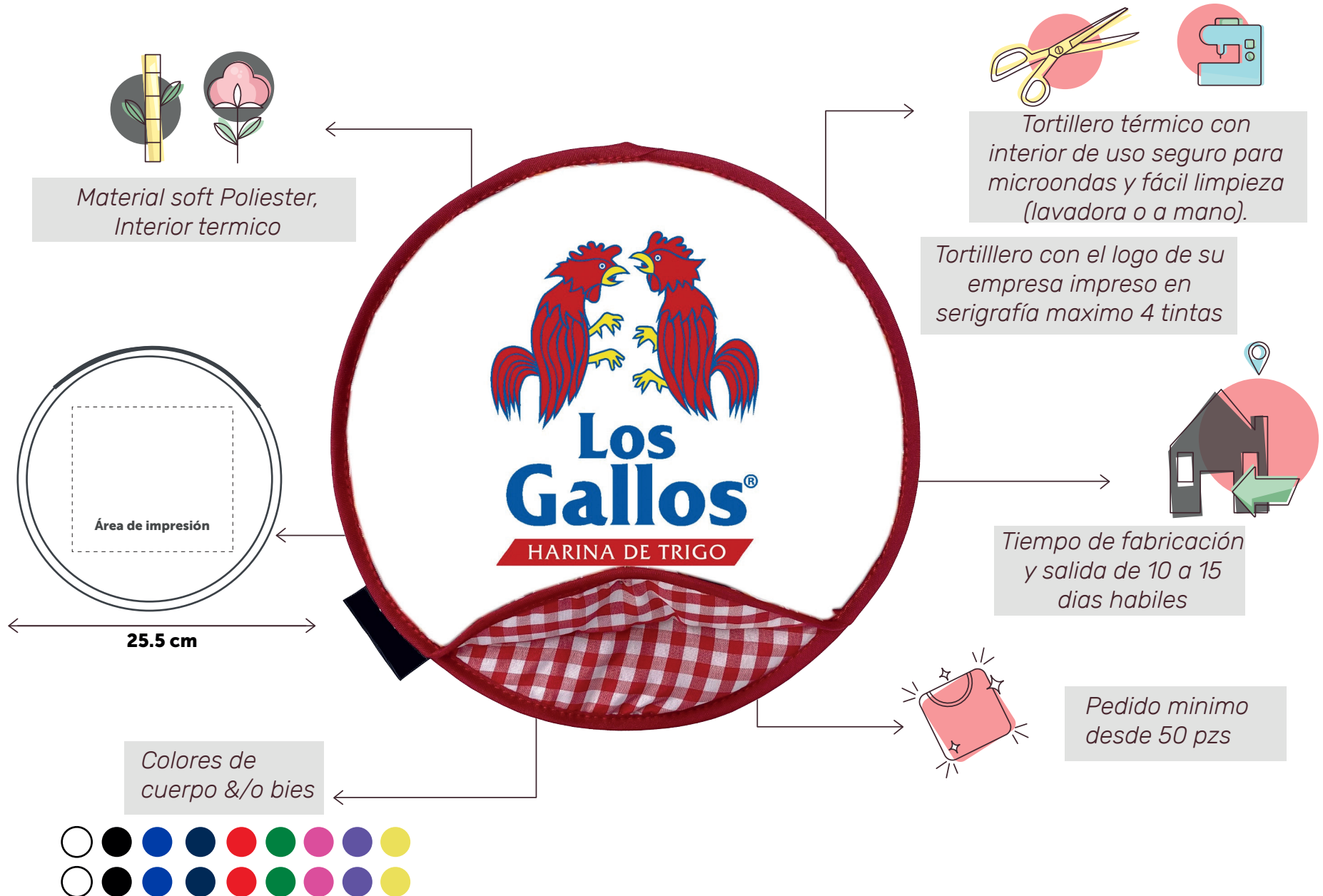

TORTILLERO TÉRMICO PARA RESTAURANTE

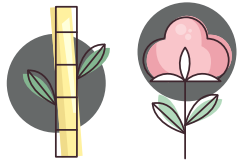

Material soft Poliester,
Interior termico



Tortillero térmico con
interior de uso seguro para
microondas y fácil limpieza
(lavadora o a mano).

Tortillero con el logo de su
empresa bordado

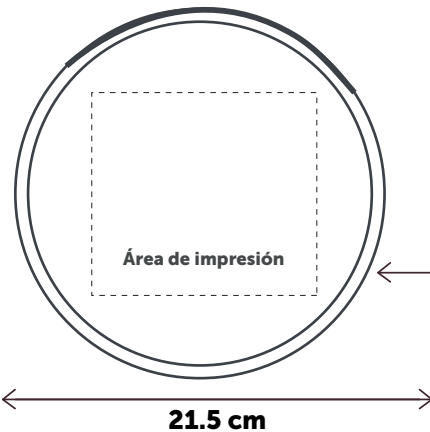

Tiempo de fabricación
y salida de 10 a 15
dias habiles

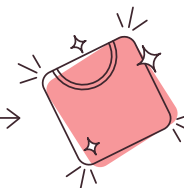

Pedido minimo
desde 50 pzs

Colores de
cuerpo &/o bias



TORTILLERO

TÉRMICO SUBLIMADO

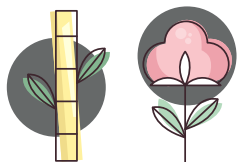

Material soft Poliester,
Interior termico

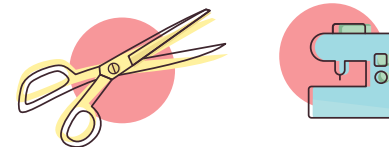

Tortillero térmico con
interior de uso seguro para
microondas y fácil limpieza
(lavadora o a mano).

Impresion a todo color en
sublimación



Tiempo de fabricación
y salida de 10 a 15
dias habiles

Pedido minimo
desde 50 pzs

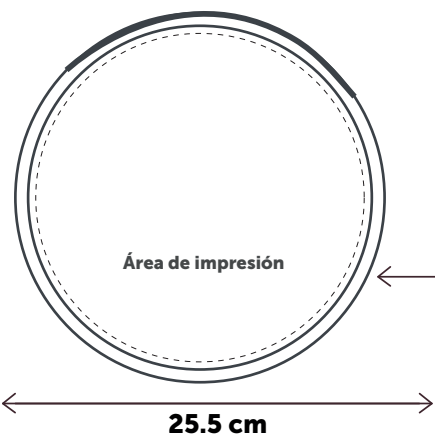

Colores de
cuerpo &/o bias



Hieleras



BEACH BAG

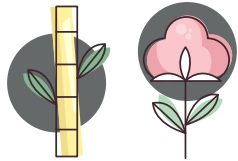

Material exterior Poliester Heavy Duty. Interior impermeable termoahulado 2 tipos de bolsa sellada. aprobadas por la FDA para contener alimentos.

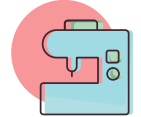
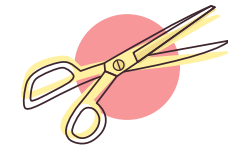

Bolsa Hielera con doble compartimiento con espacio para 12 latas de 335 ml

Impresion de larga duraci3n en serigrafía o dtf



Agarradera

22 cm

Zipper

32 cm

Área de impresi3n

15 cm

Rosarito[®]

Sabemos de sabor

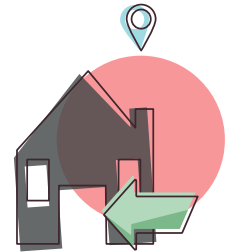

Tiempo de fabricaci3n y salida de 10 a 15 dias habiles

Colores de cuerpo & Zipper

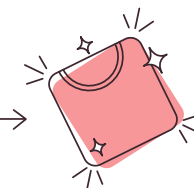

Pedido minimo desde 50 pzs

HIELERA BAZOOKA

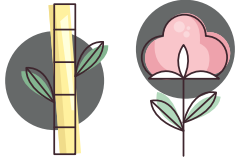

Material exterior Poliester Heavy Duty. Interior impermeable termoahulado 2 tipos de bolsa sellada. aprobadas por la FDA para contener alimentos.

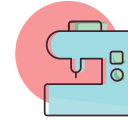

Hielera con agarradera y espacio para 6 latas de 335 ml

Impresion de larga duración en serigrafía o dtf



Tiempo de fabricación y salida de 10 a 15 días habiles

Pedido minimo desde 50 pzs

Colores de cuerpo & Zipper



HIELERA RECTANGULAR

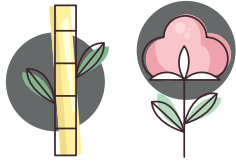

Material exterior Poliester Heavy Duty. Interior impermeable termoahulado 2 tipos de bolsa sellada. aprobadas por la FDA para contener alimentos.

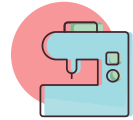

Hielera rectangular con espacio para 6 latas de 335 ml

Impresion de larga duraci3n en serigrafía o dtf

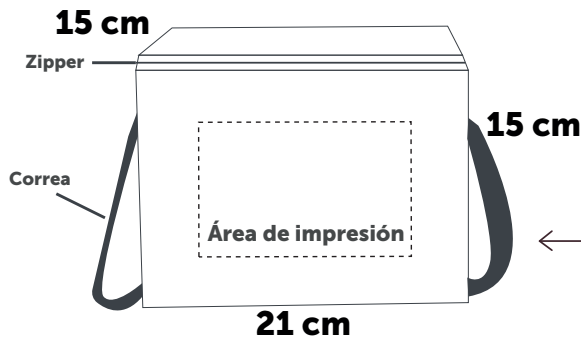

Tiempo de fabricaci3n y salida de 10 a 15 días hábiles

Colores de cuerpo & Zipper



Pedido minimo desde 50 pzs

HIELERA 12

RECTANGULAR

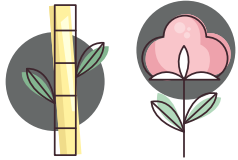

Material exterior Poliester Heavy Duty. Interior impermeable termoahulado 2 tipos de bolsa sellada. aprobadas por la FDA para contener alimentos.



Hielera rectangular con espacio para 12 latas de 335 ml

Impresion de larga duracion en serigrafía o dtf

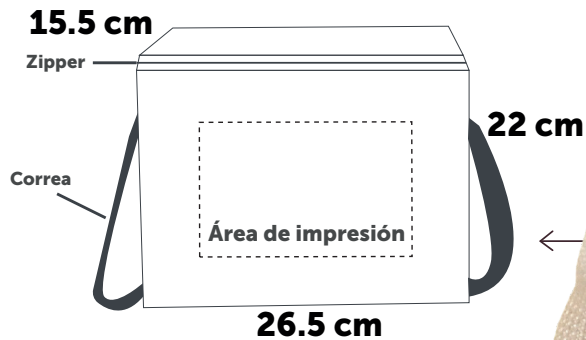

Tiempo de fabricación y salida de 10 a 15 días hábiles

Colores de cuerpo & Zipper

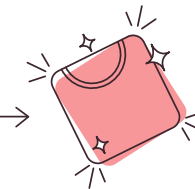

Pedido minimo desde 50 pzs

HIELERA 24

RECTANGULAR

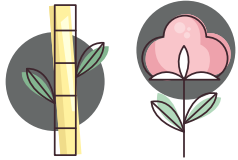

Material exterior Poliester Heavy Duty. Interior impermeable termoahulado 2 tipos de bolsa sellada. aprobadas por la FDA para contener alimentos.

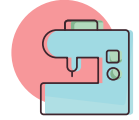

Hielera rectangular con espacio para 24 latas de 335 ml

Impresion de larga duracion en serigrafía o dtf

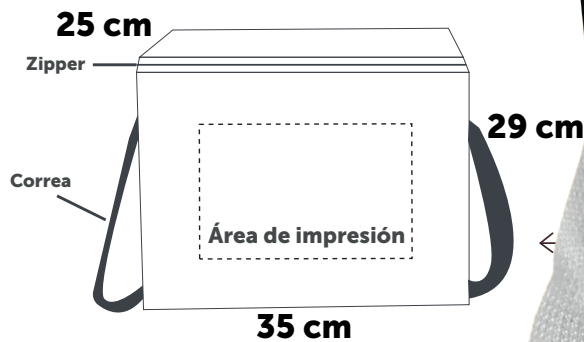

Tiempo de fabricacion y salida de 10 a 15 dias habiles

Colores de cuerpo & Zipper

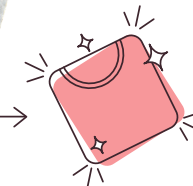

Pedido minimo desde 50 pzs

HIELERA CILINDRICA

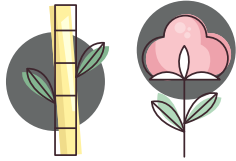

Material exterior Poliester Heavy Duty. Interior impermeable termoahulado 2 tipos de bolsa sellada. aprobadas por la FDA para contener alimentos.

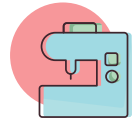
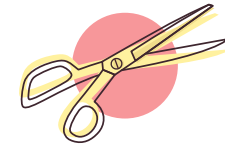

Hielera cilindrica con espacio para 12 latas de 335 ml

Impresion de larga duracion en serigrafía o dtf

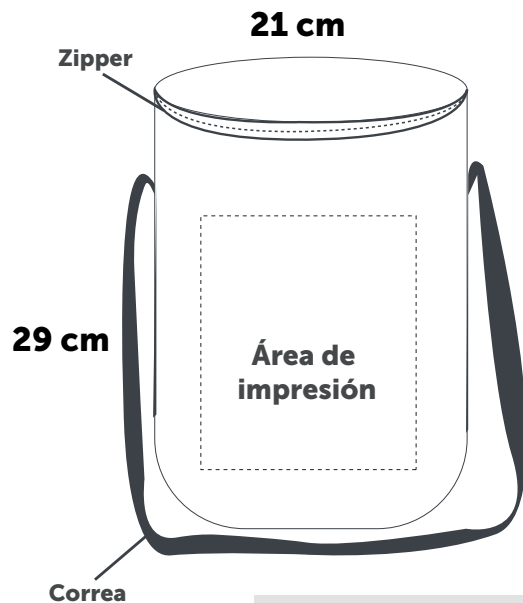

Colores de cuerpo & Zipper

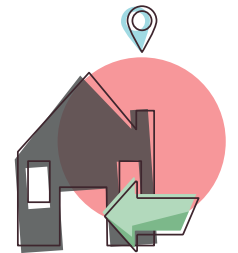

Tiempo de fabricación y salida de 10 a 15 días hábiles

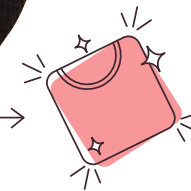

Pedido minimo desde 50 pzs

HIELERA 18

CILINDRICA

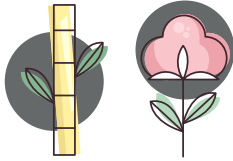

Material exterior Poliester Heavy Duty. Interior impermeable termoahulado 2 tipos de bolsa sellada. aprobadas por la FDA para contener alimentos.

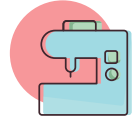
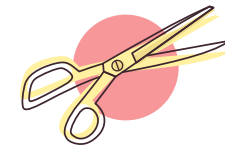

Hielera cilindrica con espacio para 18 latas de 335 ml

Impresion de larga duracion en serigrafía o dtf

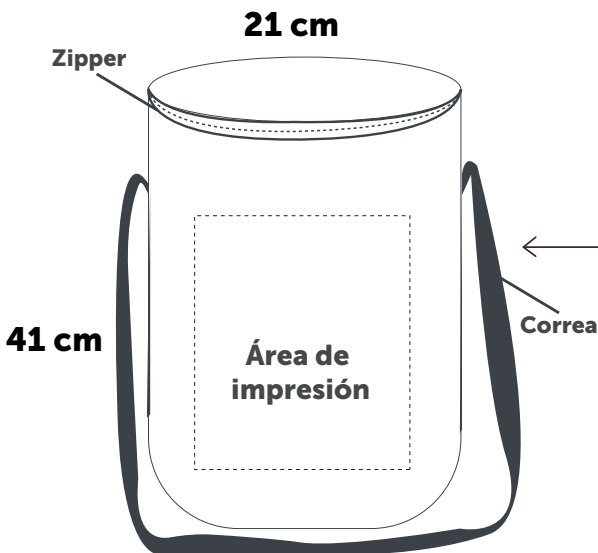

Tiempo de fabricación y salida de 10 a 15 dias habiles

Colores de cuerpo & Zipper

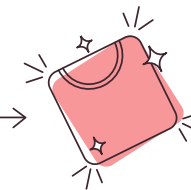

Pedido minimo desde 50 pzs

HIELERA VERTICAL

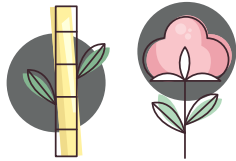

Material exterior Poliester Heavy Duty. Interior impermeable termoahulado
2 tipos de bolsa sellada.
aprobadas por la FDA para
contener alimentos.

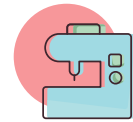
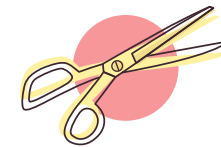

Hielera vertical con
espacio para 12 latas de
335 ml

Impresion de larga
duración en serigrafía o dtf

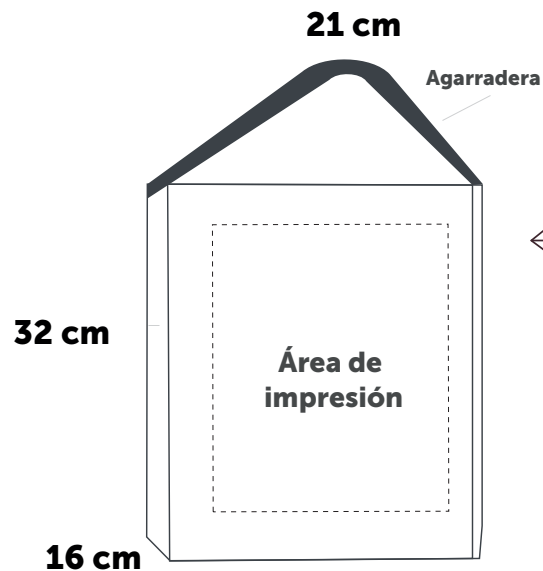

Colores de
cuerpo & Zipper



Tiempo de fabricación
y salida de 10 a 15
días habiles

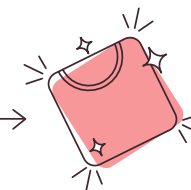

Pedido minimo
desde 50 pzs

Mandiles



MANDIL

TRIPLE-BOLSA

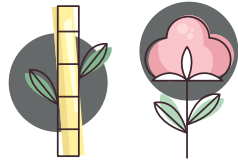

Tela Tergal

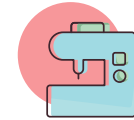

Mandil ligero y cómodo, combinable al gusto el color de tela y el bias incluye tres bolsas frontales inferiores.

Personalizalo en sefigrafía, transfer o DTF



Tiempo de fabricación y salida de 10 a 15 días hábiles

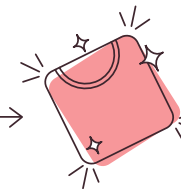

Pedido mínimo desde 50 pzs

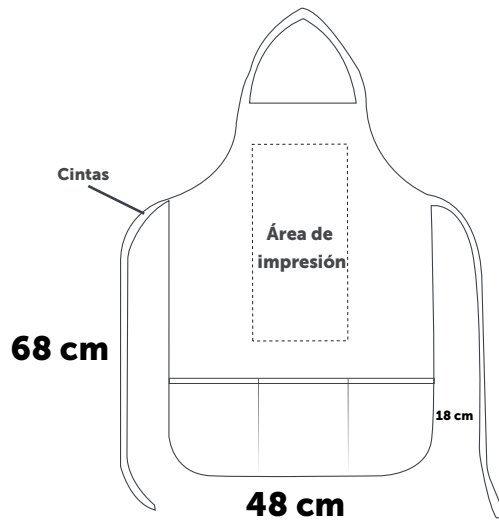

Colores de cuerpo & Bias



MANDIL GABARDINA



MANDIL PARRILLERO

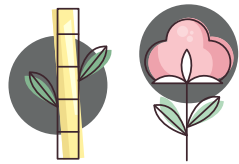

Tela Curpiel

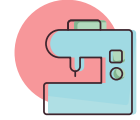
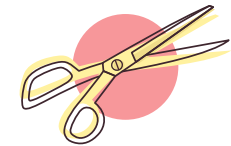

Mandil ligero y cómodo con dos bolsas frontales.

Peronalizalo en Bordado o seigrafía



Tiempo de fabricación y salida de 10 a 15 días hábiles

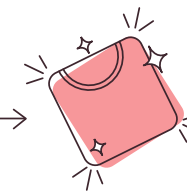

Pedido minimo desde 50 pzs

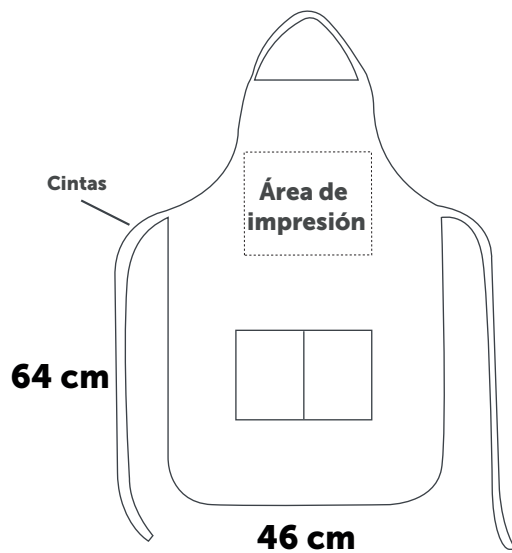

Color:



MANDIL CORTO

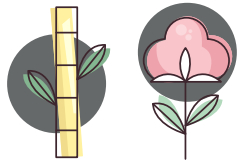

Tela Gabardina

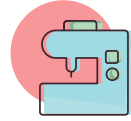
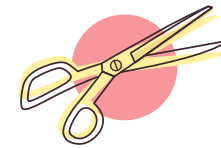

Mandil Corto o Mandil Mesero, clásico color negro, cuenta con bolsa frontal de 28 x 16 cm

Bordado



Tiempo de fabricación y salida de 10 a 15 días hábiles

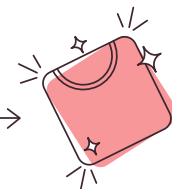

Pedido mínimo desde 50 pzs

Cintas

54 cm

Área de Bordado

50 cm

Color:



Bolsas



BOLSA MEGABAG

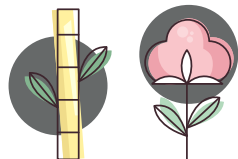

Poliéster Heavy Duty



Bolsa de gran capacidad y durabilidad. ideal para llevar al super

Personalízalo en serigrafía, transfer o DTF



Tiempo de fabricación y salida de 10 a 15 días hábiles

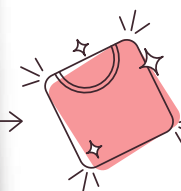

Pedido mínimo desde 50 pzs

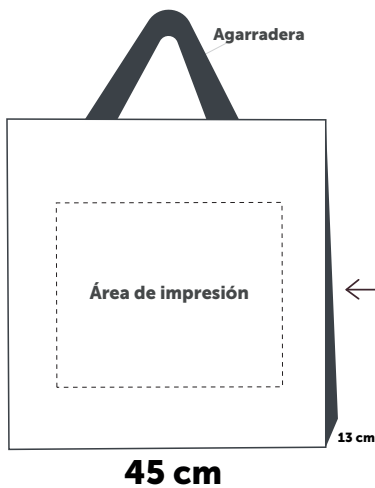

46 cm

Área de impresión

45 cm

13 cm

Colores de cuerpo & Cintas



BOLSA DE PLAYA

Poliéster Heavy Duty

30 cm

32 cm

13 cm

Agarradera

Área de impresión

BUD LIGHT

Bolsa completamente combinable, elige el color del frente, base y tirantes

Personalízalo en serigrafía, transfer o DTF

Tiempo de fabricación y salida de 10 a 15 días hábiles

Pedido mínimo desde 50 pzs

Colores de cuerpo & Cintas

-
-
-
-
-
-

PORTAFOLIO SENCILLO



PORTAFOLIO DOBLE

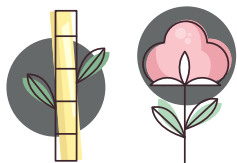

Poliéster Heavy Duty
o vinil grueso

Colores de
cuerpo & zipper



Portafolio (bank bag) con cierre superior y bolsa frontal, eligelo con o sin agarradera.

Personalízalo en serigrafía,
transfer o DTF



Tiempo de fabricación
y salida de 10 a 15
días hábiles



Pedido mínimo
desde 50 pzs

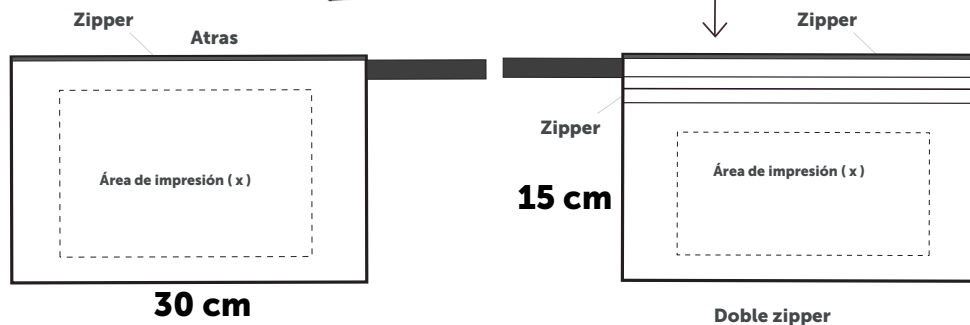

LAPICERA SENCILLA



Promotier.mx



 **644 - 179 - 90 - 15**
 **644 - 420 - 91 - 69**
 **ventas@promotier.mx**
 **552 - 272 - 76 - 52**

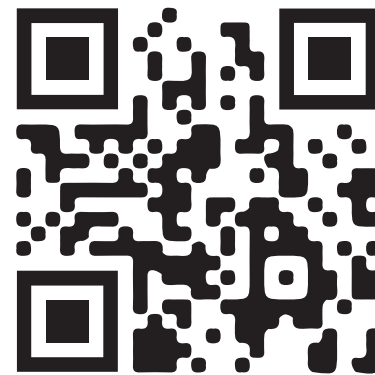

www.promotier.mx